

AXL F DI16/1 HS 1H

**Axioline F, digital input module, digital inputs: 16,
24 V DC, connection technology: 1-conductor,
input filter time < 5 μ s**



Data sheet
8610_en_02

© PHOENIX CONTACT 2021-03-23

1 Description

The module is designed for use within an Axioline F station. It is used to acquire digital signals.

Valid as of hardware revision 02, firmware revision 1.00.

Features

- 16 digital inputs according to EN 61131-2 type 1 and type 3
- 24 V DC, 2.4 mA
- Connection of sensors in 1-conductor technology
- Minimum update time of < 5 μ s, bus synchronous
- Device rating plate stored



The deviating behavior of the modules with an earlier hardware revision is documented in the corresponding points.



This data sheet is only valid in association with the UM EN AXL F SYS INST user manual.



Make sure you always use the latest documentation.
It can be downloaded at: phoenixcontact.net/product/2701722

2	Table of contents	
1	Description	1
2	Table of contents	2
3	Ordering data	3
4	Technical data	4
5	Internal circuit diagram	7
6	For your safety	7
	6.1 Intended use	7
	6.2 Qualification of users	7
	6.3 Electrical safety	7
	6.4 Installation	7
7	UL note	7
8	Terminal point assignment.....	8
9	Connection example.....	8
10	Local diagnostic and status indicators	9
11	Process data.....	10
12	Parameter, diagnostics and information (PDI)	10
13	Standard objects	11
	13.1 Objects for identification (device rating plate).....	11
	13.2 Miscellaneous standard objects	12
	13.3 Diagnostics state (0018hex: DiagState).....	13
	13.4 Input process data (0025hex: PDIN)	14
14	Device descriptions	14

3 Ordering data

Description	Type	Order No.	Pcs./Pkt.
Axioline F, Digital input module, Digital inputs: 16, 24 V DC, connection method: 1-conductor, Input filter time < 5 µs, transmission speed in the local bus: 100 Mbps, degree of protection: IP20, including bus base module and Axioline F connectors	AXL F DI16/1 HS 1H	2701722	1
Accessories	Type	Order No.	Pcs./Pkt.
Axioline F bus base module for housing type H (Replacement item)	AXL F BS H	2700992	5
Zack marker strip for Axioline F (device labeling), in 2 x 20.3 mm pitch, unprinted, 25-section, for individual labeling with B-STIFT 0.8, X-PEN, or CMS-P1-PLOTTER (Marking)	ZB 20,3 AXL UNPRINTED	0829579	25
Zack Marker strip, flat, Strip, white, unlabeled, can be labeled with: PLOTMARK, CMS-P1-PLOTTER, mounting type: snap into flat marker groove, for terminal block width: 10.15 mm, lettering field size: 4 of 10.15 x 5 mm and 1 of 5.8 x 5 mm, Number of individual labels: 50 (Marking)	ZBF 10/5,8 AXL UNPRINTED	0829580	50
Insert label, Roll, white, unlabeled, can be labeled with: THERMOMARK ROLLMASTER 300/600, THERMOMARK X1.2, THERMOMARK ROLL X1, THERMOMARK ROLL 2.0, THERMOMARK ROLL, mounting type: snapped into marker carrier, lettering field size: 35 x 28 mm, Number of individual labels: 500 (Marking)	EMT (35X28)R	0801602	1
Documentation	Type	Order No.	Pcs./Pkt.
User manual, English, Axioline F: System and installation	UM EN AXL F SYS INST	-	-
User manual, English, Axioline F: Diagnostic registers, and error messages	UM EN AXL F SYS DIAG	-	-

4 Technical data

Dimensions (nominal sizes in mm)

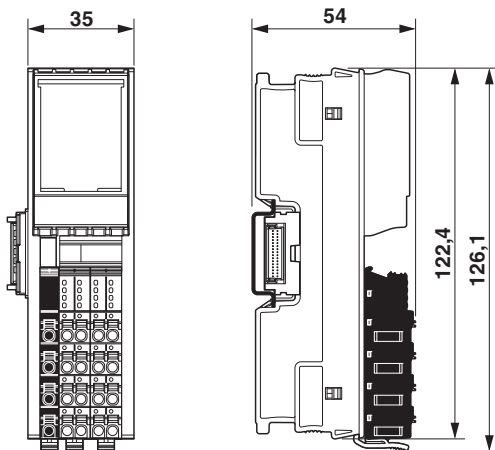

Width	35 mm
Height	126.1 mm
Depth	54 mm
Note on dimensions	The depth is valid when a TH 35-7,5 DIN rail is used (according to EN 60715).

General data

Color	traffic grey A RAL 7042
Weight	133 g (with connectors and bus base module)
Ambient temperature (operation)	-25 °C ... 60 °C
Ambient temperature (storage/transport)	-40 °C ... 85 °C
Permissible humidity (operation)	5 % ... 95 % (non-condensing)
Permissible humidity (storage/transport)	5 % ... 95 % (non-condensing)
Air pressure (operation)	70 kPa ... 106 kPa (up to 3000 m above sea level)
Air pressure (storage/transport)	70 kPa ... 106 kPa (up to 3000 m above sea level)
Degree of protection	IP20
Protection class	III (IEC 61140, EN 61140, VDE 0140-1)
Overvoltage category	II (IEC 60664-1, EN 60664-1)
Degree of pollution	2 (IEC 60664-1, EN 60664-1)
Mounting position	any (no temperature derating)

Connection data: Axioline F connector

Connection method	Push-in connection
Conductor cross section, rigid	0.2 mm ² ... 1.5 mm ²
Conductor cross section, flexible	0.2 mm ² ... 1.5 mm ²
Conductor cross section [AWG]	24 ... 16
Stripping length	8 mm



Please observe the information provided on conductor cross sections in the “Axioline F: system and installation” user manual.

Interface: Axioline F local bus

Number of interfaces	2
Connection method	Bus base module
Transmission speed	100 Mbps

Axioline F local bus supply (U_{Bus})

Supply voltage	5 V DC (via bus base module)
Current consumption	max. 120 mA (up to HW 01) max. 60 mA (as of HW 02)
Power consumption	max. 600 mW (up to HW 01) max. 300 mW (as of HW 02)

Supply for digital input modules (U_I)

Supply voltage	24 V DC
Supply voltage range	19.2 V DC ... 30 V DC (including all tolerances, including ripple)
Current consumption	max. 30 mA
Power consumption	typ. 480 mW max. 720 mW
Surge protection	electronic (35 V, 0.5 s)
Reverse polarity protection	parallel diode; with external 5 A fuse (only for commissioning)
Protection	max. 8 A (polarity reversal protection up to 5 A)



NOTE: Damage to the electronics

Provide external protection for the module to ensure reverse polarity protection. If you use a fuse, the power supply unit must be capable of supplying four times the nominal current of the fuse. This ensures that the fuse trips reliably in the event of a fault.



When using the module for the first time, protect it with a 5 A fuse. When all modules in the system are correctly connected, the 5 A fuse can be replaced with an 8 A fuse. After that, you can load the module up to 8 A.

Digital inputs

Number of inputs	16
Connection method	Push-in connection
Connection technology	1-conductor
Description of the input	EN 61131-2 types 1 and 3
Nominal input voltage	24 V DC

Digital inputs	
Nominal input current	2.3 mA
Current flow	linear until nominal current is reached, then constantly approximately 2.3 mA
Input voltage range "0" signal	-3 V DC ... 8.4 V DC
Input voltage range "1" signal	9.4 V DC ... 30 V DC
Input filter time	< 5 μ s
Process data update	< 5 μ s (bus-synchronous)
Polarity reversal protection of the inputs	parallel diode (30 V, 5 s)



The minimum update time of the module can only be fully utilized if the station is configured accordingly, as the runtime of the local bus depends on the number of connected Axioline F modules (see also Axioline system manual).

Input and output address area	
Input address area	2 Byte
Output address area	0 Byte

Configuration and parameter data in a PROFIBUS system	
Required parameter data	1 Byte
Required configuration data	6 Byte

Electrical isolation/isolation of the voltage areas	
Test section	Test voltage
5 V supply of the local bus (U_{BUS}) / 24 V supply (I/Os)	500 V AC, 50 Hz, 1 min.
5 V supply of the local bus (U_{BUS}) / functional ground	500 V AC, 50 Hz, 1 min.
24 V supply (I/O) / functional ground	500 V AC, 50 Hz, 1 min.

Mechanical tests	
Vibration resistance in acc. with EN 60068-2-6/ IEC 60068-2-6	5g
Shock in acc. with EN 60068-2-27/IEC 60068-2-27	30g
Continuous shock according to EN 60068-2-27/ IEC 60068-2-27	10g

Conformance with EMC Directive 2014/30/EU	
Noise immunity test in accordance with EN 61000-6-2	
Electrostatic discharge (ESD) EN 61000-4-2/ IEC 61000-4-2	Criterion B, 6 kV contact discharge, 8 kV air discharge
Electromagnetic fields EN 61000-4-3/IEC 61000-4-3	Criterion A, Field intensity: 10 V/m
Fast transients (burst) EN 61000-4-4/IEC 61000-4-4	Criterion B, 2 kV
Transient overvoltage (surge) EN 61000-4-5/ IEC 61000-4-5	Criterion B, DC supply lines: ± 0.5 kV/ ± 0.5 kV (symmetrical/ asymmetrical)
Conducted interference EN 61000-4-6/IEC 61000-4-6	Criterion A, Test voltage 10 V
Noise emission test according to EN 61000-6-3	Class B

Approvals
 For the latest approvals, please visit phoenixcontact.net/products.

5 Internal circuit diagram

Figure 1 Internal wiring of the terminal points

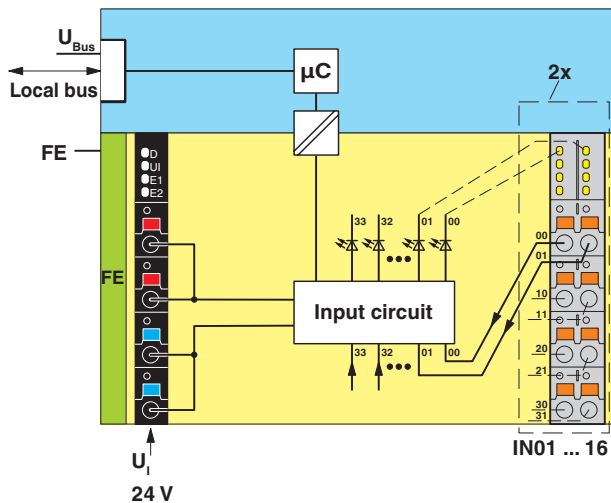

Key:

Local bus Axioline F local bus
(hereinafter referred to as local bus)

FE Functional ground
Microcontroller



Electrical isolation

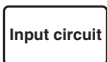

Input circuit



LED



Electrically isolated areas

6 For your safety

6.1 Intended use

Use the Axioline F modules exclusively in accordance with the specifications in the accompanying data sheet and the "Axioline F: System and Installation" user manual.

6.2 Qualification of users

The use of products described in this data sheet is oriented exclusively to electrically skilled persons or persons instructed by them. The users must be familiar with the relevant safety concepts of automation technology as well as applicable standards and other regulations.

6.3 Electrical safety



WARNING: loss of electrical safety

If used incorrectly, device safety may be impaired.

The instructions given in this data sheet as well as the UM EN AXL F SYS INST user manual must be observed during installation, startup, and operation.

6.4 Installation

Only install the Axioline F modules in a control cabinet or junction box.

The enclosure must meet the requirements regarding the protection against spread of fire according to the following standards:

- EN 61010-1/IEC 61010-1
- UL 61010-1 (for applications with UL approval)

7 UL note

- Use copper conductor only.

8 Terminal point assignment

Figure 2 Terminal point assignment

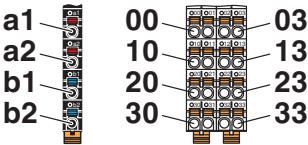

Terminal point	Color	Assignment	
Supply voltage input			
a1, a2	Red	24 V DC (U _I)	Supply for digital input modules (bridged internally)
b1, b2	Blue	GND	Reference potential of the supply voltage (bridged internally)
Digital inputs			
00 ... 03	Orange	IN01 ... IN04	Digital inputs 1 ... 4
10 ... 13	Orange	IN05 ... IN08	Digital inputs 5 ... 8
20 ... 23	Orange	IN09 ... IN12	Digital inputs 9 ... 12
30 ... 33	Orange	IN13 ... IN16	Digital inputs 13 ... 16

9 Connection example

Figure 3 Example of a connection of sensors when using external busbars

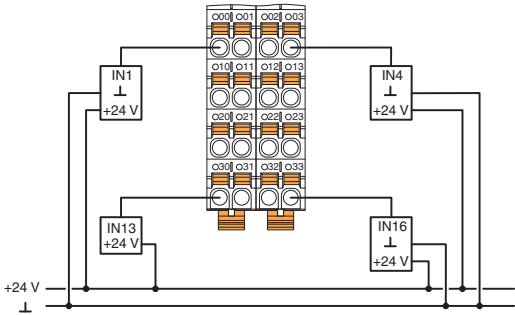

Ensure that GND of the sensors and GND for U_I have the same potential.

10 Local diagnostic and status indicators

As of hardware revision 02

Figure 4 Local diagnostic and status indicators

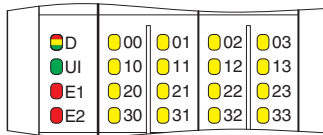

Designation	Color	Meaning	State	Description
D	Red/ yellow/ green	Diagnostics of local bus communication		
		Run	Green on	The device is ready for operation, communication within the station is OK. All data is valid. An error has not occurred.
		Active	Green flashing	The device is ready to operate, communication within the station is OK. The data is not valid. The controller or superordinate network is not delivering valid data. There is no error on the module.
		Device application not active	Green/ yellow flashing	The device is ready for operation, communication within the station is OK. Output data cannot be outputted and/or input data cannot be read. There is a fault on the periphery side of the module..
		Ready	Yellow on	The device is ready for operation but did not detect a valid cycle after power-up.
		Connected	Yellow flashing	The device is not (yet) part of the active configuration.
		Reset	Red on	The device is ready for operation but has lost the connection to the bus head.
		Not connected	Red flashing	The device is ready for operation but there is no connection to the previously existing device.
		Power down	Off	Device is in (power) reset.
UI	Green	U _{Input}	On	Supply for digital input modules (U _I) is present.
			Off	Supply for digital input modules (U _I) is not present.
E1	Red	Supply voltage error	On	Feed-in for digital input modules (U _I) is faulty.
			Off	Feed-in for digital input modules (U _I) is OK.
E2	Red	Internal device error	On	There is an internal device error.
			Off	There is no internal device error.
00 ... 03, 10 ... 13, 20 ... 23, 30 ... 33	Yellow	Status of the inputs	On	Input is set.
			Off	Input is not set.

Deviating behavior up to hardware revision 01

The LEDs E1 and E2 are not present.

11 Process data

The process data is mapped in Motorola format (Big Endian).

IN process data

Byte	0							
Bit	7	6	5	4	3	2	1	0
Signal	IN08	IN07	IN06	IN05	IN04	IN03	IN02	IN01
Terminal point	13	12	11	10	03	02	01	00

Byte	1							
Bit	7	6	5	4	3	2	1	0
Signal	IN16	IN15	IN14	IN13	IN12	IN11	IN10	IN09
Terminal point	33	32	31	30	23	22	21	20

12 Parameter, diagnostics and information (PDI)

Parameter and diagnostic data as well as other information is transmitted as objects via the PDI channel of the Axioline F station.

The standard and application objects stored in the module are described in the following section.

The following applies to all tables below:

Please refer to the UM EN AXL F SYS INST for an explanation of the data types.

Abbreviation	Meaning
A	Number of elements
L	Length of the elements in bytes
R	Read
W	Write



Each visible string is terminated with a null terminator (00_{hex}). The length of a visible-string-type element is therefore at least one byte larger than the number of user data items.

If the number of user data items plus null terminator is smaller than the specified length of the element, the visible string will be populated with a null character (00_{hex}).



For detailed information on PDI objects, please refer to the UM EN AXL F SYS INST user manual.

13 Standard objects

13.1 Objects for identification (device rating plate)

As of hardware revision 02

Index (hex)	Object name	Data type	A	L	Rights	Meaning	Contents
Manufacturer							
0001	VendorName	Visible String	1	32	R	Vendor name	Phoenix Contact
0002	VendorID	Visible String	1	7	R	Vendor ID	00A045
0003	VendorText	Visible String	1	58	R	Vendor text	Components and systems for industrial automation
0012	VendorURL	Visible String	1	58	R	Vendor URL	www.phoenixcontact.com
Module - general							
0004	DeviceFamily	Visible String	1	16	R	Device family	I/O digital IN
0006	ProductFamily	Visible String	1	32	R	Product family	AXL F
000E	CommProfile	Visible String	1	4	R	Communication profile	633
000F	DeviceProfile	Visible String	1	5	R	Device profile	0010
0011	ProfileVersion	Record of Visible Strings	2	11; 21	R	Profile version	2011-12-07; Basic - Profile V2.0
0017	Language	Record of Visible Strings	2	6; 8	R	Language	en-us; English
Module - special							
0005	Capabilities	Visible String	1	8	R	Capabilities	SyncI_0
0007	ProductName	Visible String	1	32	R	Product name	AXL F DI16/1 HS 1H
0008	SerialNo	Visible String	1	22	R	Serial number	e. g., 1234512345
0009	ProductText	Visible String	1	58	R	Product text	16 digital inputs
000A	OrderNumber	Visible String	1	32	R	Order No.	2701722
000B	HardwareVersion	Record of Visible Strings	2	11; 11	R	Hardware version	e. g., 2011-02-04; 00
000C	FirmwareVersion	Record of Visible Strings	2	11; 11	R	Firmware version	e.g., 2017-12-31; 1.00
000D	PChVersion	Record of Visible Strings	2	11; 6	R	PDI version	e. g., 2010-06-21; V1.00
0037	DeviceType	Octet string	1	8	R	Device type	00 80 00 02 00 00 00 DB _{hex}
003A	VersionCount	Array of UINT16	4	4 * 2	R	Version counter	e.g., 0007 0001 0001 0001 _{hex}
Use of the device							
0014	Location	Visible String	1	59	R/W	Location	Can be completed by the user.
0015	EquipmentIdent	Visible String	1	59	R/W	Equipment identifier	Can be completed by the user.
0016	ApplDeviceAddr	UINT16	1	2	R/W	Application-specific device address	Can be completed by the user.

Deviating behavior up to hardware revision 01

Index (hex)	Object name	Data type	A	L	Rights	Meaning	Contents
Manufacturer							
0001	VendorName	Visible String	1	16	R	Vendor name	Phoenix Contact
0003	VendorText	Visible String	1	49	R	Vendor text	Components and systems for industrial automation
0012	VendorURL	Visible String	1	30	R	Vendor URL	http://www.phoenixcontact.com
Module - general							
0006	ProductFamily	Visible String	1	33	R	Product family	Axioline - High speed I/O system
0011	ProfileVersion	Record of Visible Strings	2	11; 22	R	Profile version	2009-10-22; Basic - Profile V1.12
003A	VersionCount	UINT16	4	4 * 2	R	Version counter	e.g., 0007 0001 0000 0000 _{hex}
Module - special							
0007	ProductName	Visible String	1	19	R	Product name	AXL F DI16/1 HS 1H
0008	SerialNo	Visible String	1	11	R	Serial number	e. g., 1234512345
0009	ProductText	Visible String	1	18	R	Product text	16 digital inputs
000A	OrderNumber	Visible String	1	8	R	Order No.	2701722
000B	HardwareVersion	Record of Visible Strings	2	11; 3	R	Hardware version	e. g., 2011-02-04; 00
000C	FirmwareVersion	Record of Visible Strings	2	11; 3	R	Firmware version	0000-00-00; --

13.2 Miscellaneous standard objects

Index (hex)	Object name	Data type	A	L	Rights	Meaning/contents
Diagnostics objects						
0018	DiagState	Record	6	58	R	Diagnostic state *
Objects for process data management						
0025	PDIN	Octet string	1	2	R	Input process data *
003B	PDIN_Descr	Array of Records	3	8; 2; 2	R	Description of the IN process data
003C	PDOOUT_Descr	Array of Records	3	8; 2; 2	R	Description of the output process data

The objects identified with * in the last column are described in more detail in the following sections.

The description of the other objects is to be found in the user manual UM EN AXL F SYS INST.

The objects 003B_{hex} and 003C_{hex} are only applicable to tools.

13.3 Diagnostics state (0018_{hex}: DiagState)

This object is used for a structured message of an error.

As of hardware revision 02

0018 _{hex} : Diagnostics state (read)					
Subindex	Data type	Length in bytes	Meaning	Contents	
0	Record	58	Diagnostic state	Complete diagnostics information	
1	UINT16	2	Error number	0 ... 65535 _{dec}	
2	UINT8	1	Priority	00 _{hex}	No error
				01 _{hex}	Error
				02 _{hex}	Warning
				81 _{hex}	Error removed
				82 _{hex}	Warning eliminated
3	UINT8	1	Channel/group/module	00 _{hex}	No error
				FF _{hex}	Entire device
4	UINT16	2	Error code	See table below	
5	UINT8	1	More follows	00 _{hex}	
6	Visible String	51	Text	See table below	



The message with priority 81_{hex} or 82_{hex} is a one-off, internal message to the bus coupler. The bus coupler transfers this error message to the error mechanisms of the higher-level system.



After all errors have been eliminated, it is automatically reset.

Error and status of the local diagnostics and status indicators

Subindex	2	3	4	6	LED			
	Priority	Channel/group/module	Error code	Text	D	UI	E1	E2
Error	hex	hex	hex					
No error	00	00	0000	Status OK	●	●	○	○
Failure of the supply for digital input modules (U _i)	01	FF	3412	Missing I/O supply UI, terminal point a1/a2, b1/b2	⚡	○	●	○

- Off
- On
- Green on
- ⚡ Green/yellow flashing

Deviating behavior up to hardware revision 01

The LEDs E1 and E2 are not present.

The error codes are identical to those in hardware revision 02.

Error text is not specified.

13.4 Input process data (0025_{hex}: PDIN)

You can read the IN process data of the module with this object.

The structure corresponds to the representation in the "Process data" section.

0025 _{hex} : IN process data (read)			
Subindex	Data type	Length in bytes	Meaning
0	Octet string	2	Input process data

14 Device descriptions

The device is described in the device description files.

The device descriptions for controllers from Phoenix Contact are included in PC Worx and PLCnext Engineer, as well as in the corresponding service packs.

The device description files for other systems are available for download at phoenixcontact.net/products in the download area of the bus coupler installed.