

AXL SE AI4 U 0-10

**Axioline Smart Elements, analog input module,
analog inputs: 4, 0 V ... 10 V,
connection technology: 2-conductor**



Data sheet
108695_en_03

© Phoenix Contact 2023-03-27

1 Description

You can integrate Axioline Smart Elements into systems with the Smart Element interface.

This Smart Element detects analog voltage signals.

Features

- 4 analog input channels
- Connection of sensors in 2-conductor technology
- Voltage range: 0 V ... 10 V
- Data format: standardized representation
- Resolution: 12 bits
- Substitute value behavior can be parameterized for each input
- Device rating plate stored



This data sheet is only valid in association with the UM EN AXL SE SYS INST user manual.



Make sure you always use the latest documentation.

It can be downloaded at: phoenixcontact.net/product/1088104

2	Table of contents	
1	Description	1
2	Table of contents	2
3	Ordering data	3
4	Technical data	3
5	Tolerance data.....	6
6	Internal circuit diagram	7
7	For your safety	8
	7.1 Intended use	8
	7.2 Qualification of users	8
	7.3 Disconnecting or plugging in a Smart Element	8
	7.4 Strain relief.....	8
	7.5 Locking a Smart Element	8
	7.6 Applications with UL approval	8
8	Terminal point assignment and diagnostic indicators	9
	8.1 Terminal point assignment	9
	8.2 Local diagnostics indicator	9
9	Connection example.....	9
10	Connection notes	10
11	Process data.....	10
12	Representation of measured values	11
13	Parameter, diagnostics and information (PDI)	12
14	Standard objects	12
	14.1 Diagnostics state (0018hex: DiagState).....	13
	14.2 Handling diagnostic messages (0019hex: ResetDiag)	14
	14.3 Substitute value behavior during I/O error (PDIN) (0030hex: PF_Code).....	14
	14.4 Reset parameterization (002Dhex: ResetParam)	14
15	Device descriptions	15

3 Ordering data

Description	Type	Item no.	Pcs./Pkt.
Axioline Smart Elements, Analog input module, Analog inputs: 4, 0 V ... 10 V, connection technology: 2-conductor, degree of protection: IP20	AXL SE AI4 U 0-10	1088104	1

Documentation	Type	Item no.	Pcs./Pkt.
User manual, English, Axioline Smart Elements	UM EN AXL SE SYS INST	-	-
User manual, English, Axioline F: System and installation	UM EN AXL F SYS INST	-	-
User manual, English, Axioline F: Diagnostic registers, and error messages	UM EN AXL F SYS DIAG	-	-

Additional ordering data

For additional ordering data (accessories), go to: www.phoenixcontact.net/product/1088104

4 Technical data

Dimensions (nominal sizes in mm)

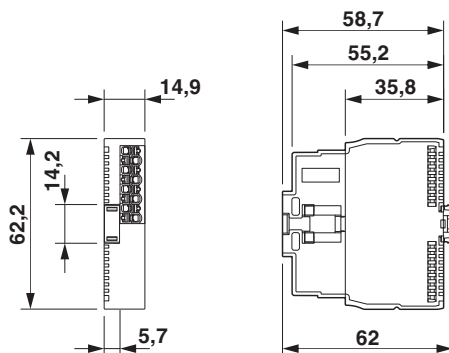

Width	14.9 mm
Height	62.2 mm
Depth	62 mm

General data

Color	traffic grey A RAL 7042
Weight	34 g
Ambient temperature (operation)	-25 °C ... 60 °C
Ambient temperature (storage/transport)	-40 °C ... 85 °C
Permissible humidity (operation)	5 % ... 95 % (non-condensing)
Permissible humidity (storage/transport)	5 % ... 95 % (non-condensing)
Air pressure (operation)	70 kPa ... 106 kPa (up to 3000 m above sea level)
Air pressure (storage/transport)	70 kPa ... 106 kPa (up to 3000 m above sea level)

General data

Degree of protection	IP20
Protection class	III (IEC 61140, EN 61140, VDE 0140-1)
Overvoltage category	II (IEC 60664-1)
Degree of pollution	2 (EN 60664-1)
Mounting type	Smart Element slot
Mounting position	See the system in which the Smart Element is used.



Do not use the Smart Element in an atmosphere that contains corrosive gas.

Connection data: I/O

Connection method	Push-in connection
Conductor cross section, rigid	0.25 mm ² ... 1.5 mm ²
Conductor cross section, flexible	0.25 mm ² ... 1.5 mm ²
Conductor cross section [AWG]	24 ... 16
Conductor cross section flexible, with ferrule with plastic sleeve	0.25 mm ² ... 1.5 mm ²
Conductor cross section flexible, with ferrule without plastic sleeve	0.25 mm ² ... 1.5 mm ²
Stripping length	8 mm



Please observe the information provided on conductor cross sections in the "Axioline Smart Elements" user manual.

Interface: Smart Element interface

Number of interfaces	1
Connection method	Card edge connector
Start time until ready to operate	< 1000 ms

Communications power supply of the Smart Elements (U_{SE})

Supply voltage	using card edge connectors
Current draw	See documentation for the system in which the Smart Element is used.

I/O supply (U_P)

Nominal supply voltage	24 V DC (using card edge connectors)
Supply voltage range	19.2 V DC ... 30 V DC (including all tolerances, including ripple)
Current consumption	min. 12 mA (without connected peripherals) typ. 15 mA max. 20 mA
Power consumption	min. 288 mW max. 480 mW
Surge protection	See the system in which the Smart Element is used.
Reverse polarity protection	Polarity protection diode
Protection	See the system in which the Smart Element is used.

Analog inputs	
Number of inputs	4
Description of the input	Single-ended inputs, voltage
Connection method	Push-in technology
Connection technology	2-conductor, shielded, twisted pair
Voltage input signal	0 V ... 10 V
Permissible voltage	max. 14 V
A/D converter resolution	12 bit
Measured value representation	16 bits
Data formats	Standardized representation
Process data update	typ. 1 ms
Tolerance, relative	typ. 0.1 % (of measuring range end value) max. 0.3 % (of measuring range end value)
Input resistance of voltage input	> 100 kΩ
Transient protection	yes

Input and output address area	
Input address area	8 Byte
Output address area	8 Byte

Configuration and parameter data in a PROFIBUS system	
Required parameter data	15 Byte
Required configuration data	6 Byte

Electrical isolation/isolation of the voltage areas	
Test section	Test voltage
Communications supply / 24 V supply (I/O)	500 V AC, 50 Hz, 1 min.
Communications supply / functional ground	500 V AC, 50 Hz, 1 min.
24 V supply (I/O) / functional ground	500 V AC, 50 Hz, 1 min.

Mechanical tests	
Vibration resistance in accordance with EN 60068-2-6/IEC 60068-2-6	5g
Shock in accordance with EN 60068-2-27/IEC 60068-2-27	30g
Continuous shock in accordance with EN 60068-2-27/IEC 60068-2-27	10g

Conformance with EMC Directive 2014/30/EU

Immunity test in accordance with EN 61000-6-2/IEC 61000-6-2

Electrostatic discharge (ESD)
EN 61000-4-2/IEC 61000-4-2 Criterion B, 6 kV contact discharge, 8 kV air discharge

Electromagnetic fields
EN 61000-4-3/IEC 61000-4-3 Criterion A, Field intensity: 10 V/m

Fast transients (burst)
EN 61000-4-4/IEC 61000-4-4 Criterion A, 2 kV

Transient overvoltage (surge)
EN 61000-4-5/IEC 61000-4-5 Criterion B, shielded I/O cables: ±1 kV asymmetrical

Conducted interference
EN 61000-4-6/IEC 61000-4-6 Criterion A, Test voltage 10 V

Noise emission test in accordance with EN 61000-6-4/IEC 61000-6-4 Class A

Approvals

For the current approvals, go to: www.phoenixcontact.net/product/1088104

Manufacturer's declarations

For the current manufacturer's declarations, go to: www.phoenixcontact.net/product/1088104

5 Tolerance data

Additional tolerances influenced by electromagnetic interference

Electromagnetic fields	EN 61000-4-3/IEC 61000-4-3	< ±0.5 %
Fast transients (burst)	EN 61000-4-4/IEC 61000-4-4	< ±0.5 %
Conducted interference	EN 61000-4-6/IEC 61000-4-6	< ±0.5 %

6 Internal circuit diagram

Figure 1 Internal wiring of the terminal points

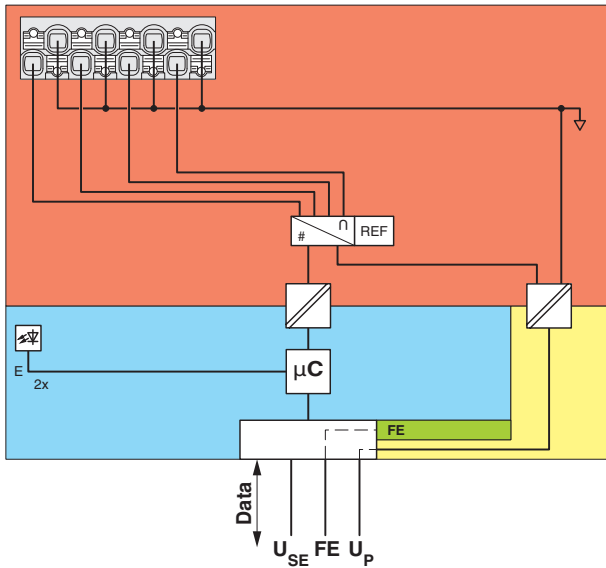

Key:

- Data Data transmission
- U_{SE} Communications power supply of the Smart Element
- FE Functional ground
- U_P I/O supply of the Smart Element
- µC Microcontroller



- LED
- Electrical isolation for data or power supply
- Analog/digital converter
- Reference voltage source
- Electrically isolated areas

7 For your safety

7.1 Intended use

Use Smart Elements exclusively in accordance with the specifications in the data sheet and the “Axiline Smart Elements” user manual.
Please also refer to the documentation for the system in which the Smart Elements are used.

7.2 Qualification of users

The use of products described in this data sheet is oriented exclusively to electrically skilled persons or persons instructed by them. The users must be familiar with the relevant safety concepts of automation technology as well as applicable standards and other regulations.

7.3 Disconnecting or plugging in a Smart Element



NOTE: Damage to contacts or malfunction

Before performing work on a Smart Element, disconnect the power to the Smart Element.

This means:

- Disconnect the connected I/O devices from the power.
- Switch off the I/O supply voltage $U_P!$
- Switch off the communications power U_{SE} .
For the system in which the Smart Element is used, this means the following: Switch off the voltage that generates the U_{SE} .

7.4 Strain relief



NOTE: damage to the contacts

Physical overloads can result in damage to the terminal points.

- Relieve strain in the connected cables.

7.5 Locking a Smart Element

Make sure that each Smart Element is locked in its slot. This is only ensured if the unlocking mechanism has been pushed into the guide as far as it will go.

See “Axiline Smart Elements” user manual.

7.6 Applications with UL approval



CAUTION!

- The external circuits intended to be connected to this device shall be galvanically separated from the mains supply or hazardous live voltage by reinforced or double insulation and meet the requirements of SELV/PELV (Class III) circuits of UL/CSA/IEC 61010-1, UL/CSA/IEC 61010-2-201.
- The device has to be installed in the final safety enclosure, which has adequate rigidity according to UL 61010-1, UL 61010-2-201 and meets the requirements with respect to spread of fire.



Information:

To install the device in accordance with UL/CSA/IEC standard, the following notes must be observed.

- If the equipment is not used in specified manner, the protection provided by the equipment may be impaired.
- Minimum temperature rating of the cables to be connected to the field wiring terminals:
85 °C, AWG 24 ... 16
- Use copper conductors only.

8 Terminal point assignment and diagnostic indicators

Figure 2 Terminal point assignment and diagnostic indicators

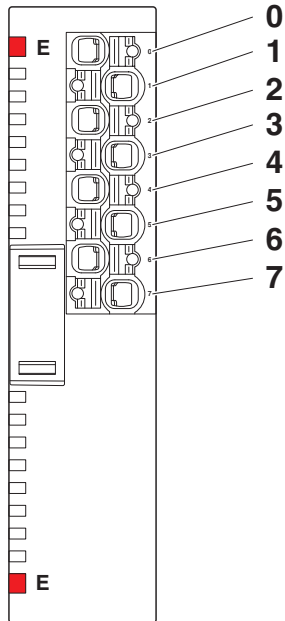

8.1 Terminal point assignment

Terminal point	Assignment	Channel	Signal
0	Analog input	1	IN01
1	Reference potential	1 ... 4	GND
2	Analog input	2	IN02
3	Reference potential	1 ... 4	GND
4	Analog input	3	IN03
5	Reference potential	1 ... 4	GND
6	Analog input	4	IN04
7	Reference potential	1 ... 4	GND

8.2 Local diagnostics indicator

Designation	Color	Description	
E	Red	Error	
		Off	No error
		Flashing (0.5 Hz)	Error in Smart Element Replace the Smart Element.
		Flashing (4 Hz)	Communication error Check whether the Smart Element has been plugged in correctly.
	On	I/O error Check the connected components and wiring. Remove the error.	

See also "Diagnostic state (0018_{hex}: DiagState)" section, "Possible error codes" table.

9 Connection example

Figure 3 Connecting the sensors

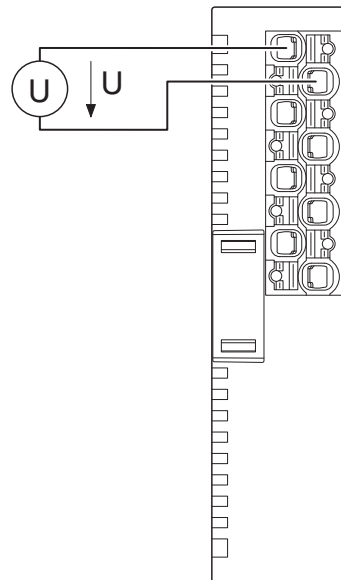

10 Connection notes



Observe the connection notes by the sensor manufacturer.

Shielding

Always connect the analog sensors using shielded, twisted pair cables.

In environments with high levels of interference, unshielded cables may cause values to be outside the specified tolerance limits.

For installation in a control cabinet: Connect the cable shield to the functional ground at a suitable point immediately after entry into the control cabinet. Route the cable in the control cabinet in a shielded manner.

If a closed control cabinet is not available, connect the shield to a shield bus.

Connect the shielding in accordance with the specifications for the system in which you are using the Smart Element.

Within an Axioline F station, the AXL SHIELD SET Axioline shield connection set is available for optimal connection directly in front of the module, see user manual UM EN AXL F SYS INST.

In general, you can use Phoenix Contact products for shielding, see www.phoenixcontact.net/webcode/#0845.

Strain relief

Do not use the shield contact as a strain relief. Carry out the shielding and the strain relief separately.

11 Process data

The process data is mapped in Motorola format (Big Endian).

The Smart Element occupies four words of input process data and four words of output process data.

Each channel is mapped to a word.

The measured values are transmitted to the higher-level system via the input process data words.

The output process data words are not relevant.

Order of the input process data words

Word	0	1	2	3
Signal	IN01	IN02	IN03	IN04
Value	AV01	AV02	AV03	AV04

AV Analog value

The measured values are depicted in standardized representation format.

In this format, data is standardized to the measuring range. Data is represented in such a way that it indicates the corresponding value without conversion.

The measured value is represented in 16 bits.

15	14	13	12	11	10	9	8	7	6	5	4	3	2	1	0
Analog value															

12 Representation of measured values

Input data		0 V ... 10 V
hex	dec	V
8001	Measuring range exceeded (overrange)	> +10.837
2A55	10837	+10.837
2710	10000	+10.0
1388	5000	+5.0
0001	1	+0.001
0000	0	0
0000	0	< 0

In the default setting, in the event of an I/O error the diagnostic code is mapped to the input process data. If the Smart Element should behave differently in the event of an I/O error, you can parameterize this accordingly. See “Substitute value behavior during I/O error (PDIN) (0030_{hex}: PF_Code)”.

Diagnostic codes	
Code (hex)	Meaning
8001	Measuring range exceeded (overrange)
8010	Parameter error
8020	I/O supply voltage (U_P) is not present.
8040	Smart Element faulty
8080	Below measuring range (underrange)

13 Parameter, diagnostics and information (PDI)

Parameter and diagnostic data as well as other information are transmitted as objects via the PDI channel.

For more detailed information on all possible standard objects for Axioline Smart Elements, please refer to the UM EN AXL SE SYS INST user manual.

The standard objects necessary for operation are described in the following section.

The following applies for the tables below:

Abbreviation	Meaning
A	Number of elements
L	Length of the elements in bytes
R	Read
W	Write

14 Standard objects

Index (hex)	Object name	Data type	A	L	Rights	Meaning/contents	Startup parameters	
Device type								
0037	DeviceType	Octet string	1	8	R	Device type 0020 0008 0000 1A0D _{hex}	No	
Diagnostics objects								
0018	DiagState	Record	11	74	R	Diagnostic state	No	*
0019	ResetDiag	UINT8	1	1	R/W	Handling diagnostic messages	No	*
Objects for process data management								
0025	PDIN	Octet string	1	8	R	Input process data The structure corresponds to the representation in the "Process data" section.	No	
0026	PDOUT	Octet string	1	8	R	OUT process data, not applicable	No	
0030	PF_Code	Array of UINT16	4	4 * 2	R/W	Substitute value behavior during I/O error (PDIN)	Yes	*
Objects for device management								
002D	ResetParam	UINT8	1	1	R/W	Reset parameterization	No	*

Startup parameters are stored permanently in the Flash memory.

The objects identified with * in the last column are described in more detail in the following sections.

The description of the other objects is to be found in the user manual UM EN AXL F SYS INST.

14.1 Diagnostics state (0018_{hex}: DiagState)

This object is used for a structured message of an error.

A detailed description of the object is provided in user manual UM EN AXL F SYS INST.

Possible error codes

Subindex	02	03	04	08	0B		
Error	Priority	Channel	Error code	Function group	Text	E LED	Corrective
	hex	hex	hex				
No error	00	00	0000	General	Status OK	○	
I/O supply voltage (U _P) is not present.	01	FF	3130	General	Supply missing (U _P)	●	Check the supply voltage.
Error in the Smart Element firmware	01	FF	6100	General	Firmware error, update required	●	Replace the Smart Element.
Problem communicating with the Smart Element	01	FF	6130	General	Smart Element missing	☀	Check whether the Smart Element has been plugged in correctly. If the error is still present, replace the Smart Element.
Fault in the Smart Element firmware	01	FF	6302	General	Firmware defect	☀	Replace the Smart Element.
Error in the parameter memory	01	FF	6320	General	Parameter error, repeat parameterization	●	Error in the parameter memory. Parameterize the Smart Element.
Measuring range violated (overrange)	02	FF	8910	AI	Overrange	○	Check the wiring.
Measuring range violated (underrange)	02	FF	8920	AI	Underrange	○	Check the wiring.

Key

Priority	00 _{hex}	No error
	01 _{hex}	Error
	02 _{hex}	Warning
Channel	00 _{hex}	No error
	FF _{hex}	Entire device

LED	○	Off
	●	On
	☀	Flashing (0.5 Hz)
	☀	Flashing (4 Hz)

14.2 Handling diagnostic messages (0019_{hex}: ResetDiag)

You can use this object to specify how the Smart Element should handle diagnostic messages.

Handling diagnostic messages	
Value (hex)	Meaning
00	Permit all diagnostic messages
02	Delete and acknowledge all diagnostic messages that are still pending
06	Delete and acknowledge all diagnostic messages and do not permit new diagnostic messages
Other	Reserved

14.3 Substitute value behavior during I/O error (PDIN) (0030_{hex}: PF_Code)

This object is used to parameterize the substitute value that is to be transmitted via the input process data in the event of an I/O error for each channel.

0030 _{hex} : Substitute value behavior during I/O error (PDIN) (read, write)			
Subindex (hex)	Data type	Length in bytes	Meaning
00	Array of UINT16	4 * 2	Read or write entire object.
01	UINT16	2	Substitute value behavior channel 1
:	:	:	:
04	UINT16	2	Substitute value behavior channel 4

Substitute value behavior	
Value (hex)	Meaning
0000	Set input value to zero value (0 V)
0001	Set input value to final value (10 V)
0002	Hold last value
0004	Map diagnostic code to the input process data (default)
Other	Reserved

Diagnostic codes	
Code (hex)	Meaning
Diagnostic codes that are mapped to the input process data regardless of the parameterization	
8010	Parameter error
8040	Smart Element faulty
Diagnostic codes that are only mapped to the input process data when parameterized accordingly	
8001	Measuring range exceeded (overrange)
8020	I/O supply voltage (U _P) is not present.
8080	Below measuring range (underrange)

14.4 Reset parameterization (002D_{hex}: ResetParam)

Use this object to reset certain parameters to the factory default settings (default values).

To reset the parameters, value 01_{hex} must be transferred during write access.

Reset the following parameters using this object:

Index (hex)	Object name	Meaning
0030	PF_Code	Substitute value behavior during I/O error (PDIN)

15 Device descriptions

The device is described in the device description files.

The device descriptions for controllers from Phoenix Contact are included in PC Worx and PLCnext Engineer, as well as in the corresponding service packs.

The device description files for other systems are available for download at www.phoenixcontact.net/products in the download area of the bus coupler installed.