

aerospace
climate control
electromechanical
filtration
fluid & gas handling
hydraulics
pneumatics
process control
sealing & shielding



Hi-Drive Series

Flexible Servo Drive



ENGINEERING YOUR SUCCESS.



WARNING – USER RESPONSIBILITY

FAILURE OR IMPROPER SELECTION OR IMPROPER USE OF THE PRODUCTS DESCRIBED HEREIN OR RELATED ITEMS CAN CAUSE DEATH, PERSONAL INJURY AND PROPERTY DAMAGE.

- This document and other information from Parker-Hannifin Corporation, its subsidiaries and authorized distributors provide product or system options for further investigation by users having technical expertise.
- The user, through its own analysis and testing, is solely responsible for making the final selection of the system and components and assuring that all performance, endurance, maintenance, safety and warning requirements of the application are met. The user must analyze all aspects of the application, follow applicable industry standards, and follow the information concerning the product in the current product catalog and in any other materials provided from Parker or its subsidiaries or authorized distributors.
- To the extent that Parker or its subsidiaries or authorized distributors provide component or system options based upon data or specifications provided by the user, the user is responsible for determining that such data and specifications are suitable and sufficient for all applications and reasonably foreseeable uses of the components or systems.

Overview	5
Technical Characteristics.....	7
Technical Data.....	7
Ambient Conditions.....	7
Standards and Conformance	7
Dimensions	8
Connection Layout	8
Accessories and Options	9
Keypad.....	9
Cables.....	9
Fieldbus Options	9
Axis Board	10
Software	11
Order Code.....	12

Parker Hannifin

The global leader in motion and control technologies

A world class player on a local stage

Global Product Design

Parker Hannifin has more than 40 years experience in the design and manufacturing of drives, controls, motors and mechanical products. With dedicated global product development teams, Parker draws on industry-leading technological leadership and experience from engineering teams in Europe, North America and Asia.

Local Application Expertise

Parker has local engineering resources committed to adapting and applying our current products and technologies to best fit our customers' needs.

Manufacturing to Meet Our Customers' Needs

Parker is committed to meeting the increasing service demands that our customers require to succeed in the global industrial market. Parker's manufacturing teams seek continuous improvement through the implementation of lean manufacturing methods throughout the process. We measure ourselves on meeting our customers' expectations of quality and delivery, not just our own. In order to meet these expectations, Parker operates and continues to invest in our manufacturing facilities in Europe, North America and Asia.

Electromechanical Worldwide Manufacturing Locations

Europe

Littlehampton, United Kingdom
Dijon, France
Offenburg, Germany
Filderstadt, Germany
Milan, Italy

Asia

Wuxi, China
Jangan, Korea
Chennai, India

North America

Rohnert Park, California
Irwin, Pennsylvania
Charlotte, North Carolina
New Ulm, Minnesota



Offenburg, Germany

Local Manufacturing and Support in Europe

Parker provides sales assistance and local technical support through a network of dedicated sales teams and authorized technical distributors throughout Europe.

For contact information, please refer to the Sales Offices on the back cover of this document or visit www.parker.com



Milan, Italy



Littlehampton, UK



Filderstadt, Germany



Dijon, France

Flexible Servo Drive - Hi-Drive

Overview

Description

Hi-Drive is a fully digital drive for brushless motors with currents from 2 to 450 A and operating from 230 VAC or 480 VAC supplies. Hi-Drive is able to control induction motors; its target market is where high precision, accuracy, performance, fieldbus connectivity and custom applications are required.

Hi-Drive features several built-in motion control functions, including current, torque and speed control, positioning with trapezoidal profiles, digital lock with variable ratio and phase correction, electronic cam, real-time mode, S-ramp positioning, homing functions and position capture.

An axis card with Power PC 400 MHz micro processor which is able to control up to 32 interpolated axes via CANopen DS402, further enhances the Hi-Drive functionality.

The Hi-Drive series is suited for simple as well as extremely sophisticated applications such as: Printing machines, wood and metal working machines, feeders, palletizers, applications with different interpolated axes and robots.

Features

- Current, torque and speed control
- Positioner with trapezoidal profile and S-ramps
- Digital lock with variable ratio and phase correction
- Electronic cam
- Configurable feedback input
- Configurable second encoder input
- Fieldbus RS232, RS422/485, SBCCan, EtherCAT, CANopen DS402, PROFINET
- DC bus connection to clamping board is possible (mono or three-phased)
- Built-in braking resistor (to 45 A)
- Built-in EMC filter: HID2...HID10, HID75...HID450
- Built-in three-phased line choke (HID75...HID155)



Technical Characteristics - Overview

Device	Nominal current [A]	Peak current [A]	Peak current time [s]	Frame size
HID2	2	4	2	1
HID5	5	10		
HID8	8	16		
HID10	10	20		2
HID15	15	30		
HID16	16	32		
HID25	25	50		
HID35	35	70	3	3
HID45	45	90		
HID75	75	135		4
HID100	100	180		5
HID130	130	234		
HID155	155	232		
HID250	250	375	6	
HID450	450	675	-	

Applications

Trajectory control of a six axis vertical robot

This is a six axis vertical robot that drives the globe in order to direct a laser pointer on the desired city, selected from the onboard operator panel or from a remote interface. The application is driven by six servo drives, controlled by a CN board integrated in one of the drives. In the board resides the interpolation and transformation part of the robot coordinates. The data for the optimized trajectory are transmitted to the individual axes via CANopen with DSP402 profile, at defined times by the sync protocol. In order to reach motion uniformity, the controller card transmits the demand speed together with the optimized motion data. Thus, every servo drive can internally execute a cubical interpolation of the information received. Moreover at every synch the real CN quota are sent back to the six joints.



The human-machine interface is represented by an industrial PC. By the PC, the operator choose in a graphical globe the city it wants to reach and gives the start/stop command.

Technical Characteristics

Technical Data

Hi-Drive

Model		HID2	HID5	HID8	HID10	HID15	HID16	HID25
	Unit							
Supply voltage and device currents								
Supply voltage	[V]	200...277 VAC single phase(±10 %) 50-60 Hz (±5 %) 200...480 VAC three phase (±10 %) 50-60 Hz (±5 %)						
Nominal current	[A]	2	5	8	10	15	16	25
Peak current	[A]	4	10	16	20	30	32	50
Peak current time	[s]	2						
Control Voltage	[V]	24 VDC (0/ +10 %)						
Overload		200 % for 2 s						

Model		HID35	HID45	HID75	HID100	HID130	HID155	HID250	HID450	
	Unit									
Supply voltage and device currents										
Supply voltage	[V]	200...480 VAC three phase (±10 %) 50-60 Hz (±5 %)			380...480 VAC three phase (±10 %) 50-60 Hz (±5 %)					
Nominal current	[A]	35	45	75	100	130	155	250	450	
Peak current	[A]	70	90	135	180	234	232	375	675	
Peak current time	[s]	2			3					4.5
Control Voltage	[V]	24 VDC (0/ +10 %)								
Overload		200 % for 2 s								

Ambient Conditions

Temperature range	Operating temperature 0...45 °C
Tolerated humidity	<85 % non condensing
Elevation of operating site	1000 m ASL (derate by 1.5 % every 100 m)
Product Enclosure Rating	IP20

Standards and Conformance

In compliance with Directive 89/336/EEC following the standard:	<ul style="list-style-type: none"> EN61800-3 (I° and II° environment) with built-in filter when available/A11 Electromagnetic Compatibility
In compliance with Directive 73/23/EEC following the standard:	<ul style="list-style-type: none"> EN 50178 (Safety, Low Voltage Directive) EN 60204-1 EN 61800-2 EN 61800-5-1
Safety technology	Optional built-in Safety relay cat. 3 in accordance with EN ISO 13849-1:2006 and EN ISO 13849-2:2008 - not certified according the latest standard
Conformance CE and UL	<ul style="list-style-type: none"> UL508C (USA) CSA 22.2 No. 14-05 (Canadian) CE marked
ATEX	for use in or in connection with potentially explosive environments

Dimensions

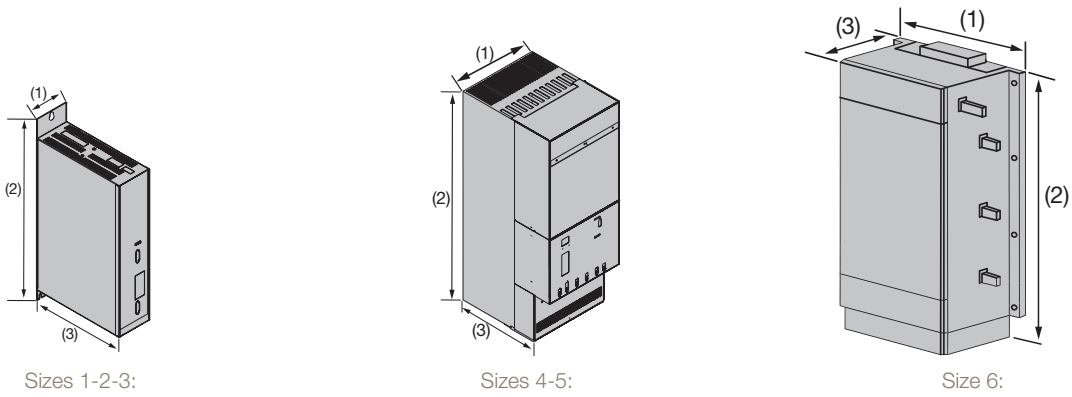

Sizes 1-2-3:

Sizes 4-5:

Size 6:

Model	Frame size	Height (2) [mm]	Width (1) [mm]	Depth (3) [mm]	Weight [kg]
HID 2-5-8-10-15	1	428	87	227	5.8
HID 15					-
HID 16-25	2	428	122	227	8.5
HID 35-45	3		227		16
HID 75	4	660	250	320	40
HID 100-130-155	5	720		365	59
HID 250	6	1145	600	465	100
HID 450	-	1400	900	465	-

Connection Layout

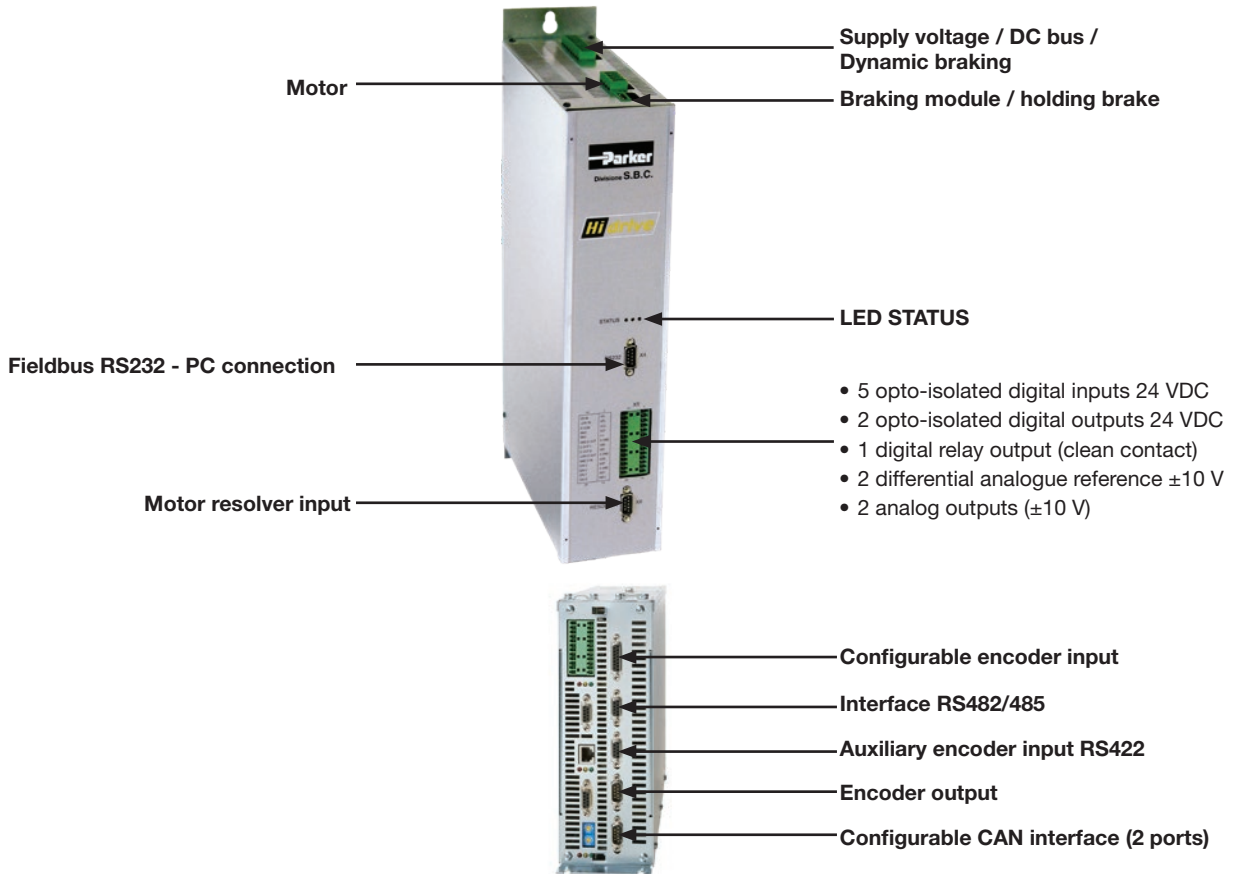

Accessories and Options

Keypad

SK161

Optional keypad, size 2x6 characters with upload/download functions (port RS232)



Cables

- Resolver cable
- Incremental encoder cable
- Absolute encoder EnDat + SinCos cable
- Absolute encoder Hiperface + SinCos cable
- Encoder SinCos cable
- Motor cable
- Servoventilation cable



Fieldbus Options

By selecting one of the numerous fieldbus options the Hi-Drive becomes a highly versatile networked drive. EtherCAT based on the Ethernet industry standard, has been implemented within the Hi-Drive to exploit operating performance of industrial PC's.

- EtherCAT
- CANopen (DS402)
- Profibus DP
- PROFINET
- SBCCan (standard)



EtherCAT®

CANopen

PROFI®
BUS

PROFI®
NET

Axis Board

High performances CN

This board is an axis controller which can be integrated into the Hi-Drive in order to increase the servo drive performance.

The board can generate trajectories of "n" interpolated axes with a low dissipated power, piloting the slave axis via CANopen DSP402.

Managing resident I/O and field bus remote I/O the CN board can be linked to the plant network or to any operator panels via Ethernet TCP/IP. The board is equipped with an embedded OPC server.

Equipped with a multitasking real time operating system and can be programmed using standard programming and motion control languages.

- Power PC 400 MHz microprocessor
- Real time multitasking RTE operating system
- Cycle tasks, event control and background
- Interpolation of up to 32 axes for CPU
- CANopen DS402 communication channels
- Libraries with a wide range of function blocks
- 64 MB RAM, 128 MB extractable flash memory and 128 kB EEPROM
- RS232, RS485 and Ethernet



Programming language	
Structured text	for motion control functions
Ladder diagram	for machine cycles programming
ISO	for tool machines programming
RHLL	for robot programming

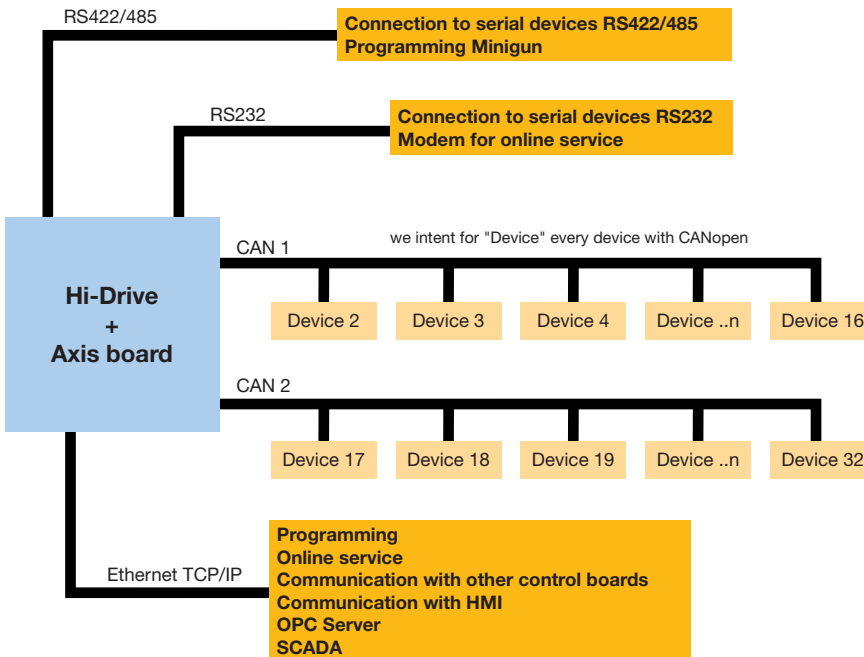

Software

MotionWiz and LogicLab

The free MotionWiz configuration software is available to configure the Hi-Drive system with just a few clicks of the mouse. MotionWiz features a simple and user-friendly interface to speed up installation, optimization and diagnostics procedures. To simplify configuration, MotionWiz shows a typical Windows® environment on the monitor with dialogue windows and toolbars. MotionWiz permits performing operations in both "online" mode, directly in the device, and in "offline" mode on a remote PC. In this case, personalized configuration can be sent to the mechanism subsequently. To simplify the configuration of systems with a large number of axis but with different cuts and the same operating mode, MotionWiz permits maintaining the same mechanism configuration and only changing the type of selected motor. Inside the MotionWiz configurator is a database containing the data of standard Parker motors. MotionWiz incorporates "picoPLC", a built-in PLC environment programmable with standard languages. PicoPLC allows the external word to communicate with the drive and to execute function sequences. If the customer application requires additional calculation resources, an option board programmable with PLC commands in accordance with IEC61131-3 can be inserted.

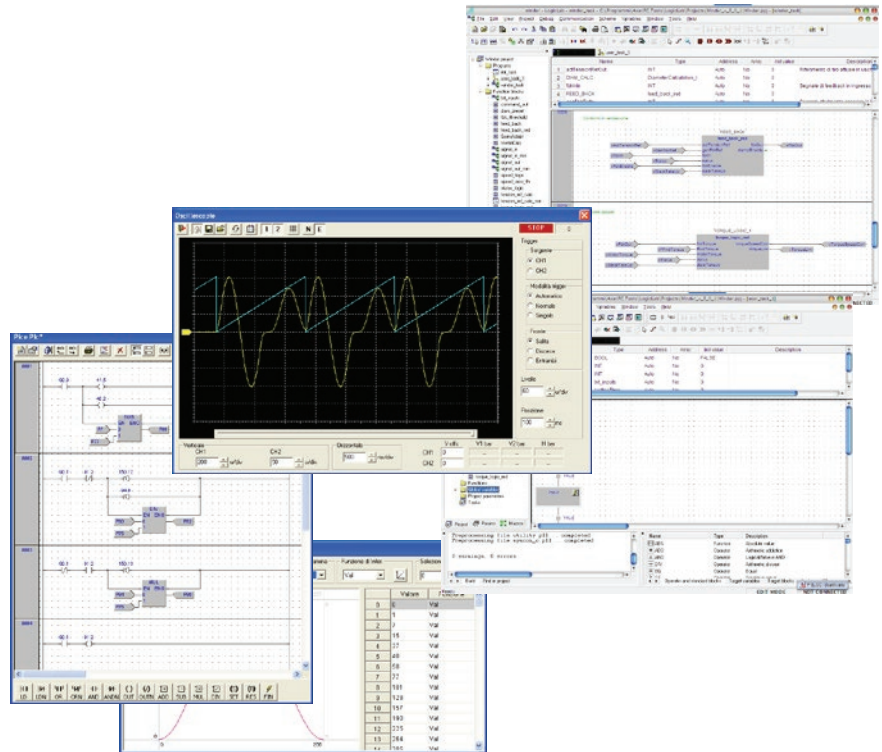

Order Code

Hi-Drive

	1	2	3	4	5	Y1	Y2	Y3	9	10
Order example	HID	X	2	S	S	I	E5	C2	R	M

1	Device family
HID	Servo drive
2	Version
Empty field	Standard version
X	ATEX device version
3	Device current (nominal current rms)
2	2 A
5	5 A
8	8 A
10	10 A
15	15 A
16	16 A
25	25 A
35	35 A
45	45 A
75	75 A
100	100 A
130	130 A
155	155 A
250	250 A
450	450 A
4	Protocol
S	SBCCan (standard)
D	CANopen (DS402)

5	Second input encoder
S	for SinCos - 1 V _{pp} signal
E	for digital signals after quadrature - RS422
H	for SinCos signal + Hall sensor
Y1...Y3	Option cards (slot1, slot2, slot3)
Empty field	without option
P	PROFIBUS DP
I	I/O option (8 digital inputs, 8 digital outputs)
E5	EtherCAT
P1	PROFINET
C	Axis board, without compact flash
C1	Axis card for up to 1.5 axes (with CANopen DS402)
C2	Axis card for up to 4 axes (with CANopen DS402)
C3	Axis card for up to 32 axes (with CANopen DS402)
9	Safety technology
Empty field	without option
R	Built-in Safety relay (not certified according the latest standard) - see details page 7
ge 7	Memory
Empty field	without option
M	Memory area for retentive variables



Parker's Motion & Control Technologies

At Parker, we're guided by a relentless drive to help our customers become more productive and achieve higher levels of profitability by engineering the best systems for their requirements. It means looking at customer applications from many angles to find new ways to create value. Whatever the motion and control technology need, Parker has the experience, breadth of product and global reach to consistently deliver. No company knows more about motion and control technology than Parker. For further info call 00800 27 27 5374



Aerospace

Key Markets

Aftermarket services
Commercial transports
Engines
General & business aviation
Helicopters
Launch vehicles
Military aircraft
Missiles
Power generation
Regional transports
Unmanned aerial vehicles

Key Products

Control systems & actuation products
Engine systems & components
Fluid conveyance systems & components
Fluid metering, delivery & atomization devices
Fuel systems & components
Fuel tank inerting systems
Hydraulic systems & components
Thermal management
Wheels & brakes



Climate Control

Key Markets

Agriculture
Air conditioning
Construction Machinery
Food & beverage
Industrial machinery
Life sciences
Oil & gas
Precision cooling
Process
Refrigeration
Transportation

Key Products

Accumulators
Advanced actuators
CO₂ controls
Electronic controllers
Filter driers
Hand shut-off valves
Heat exchangers
Hose & fittings
Pressure regulating valves
Refrigerant distributors
Safety relief valves
Smart pumps
Solenoid valves
Thermostatic expansion valves



Electromechanical

Key Markets

Aerospace
Factory automation
Life science & medical
Machine tools
Packaging machinery
Paper machinery
Plastics machinery & converting
Primary metals
Semiconductor & electronics
Textile
Wire & cable

Key Products

AC/DC drives & systems
Electric actuators, gantry robots & slides
Electrohydraulic actuation systems
Electromechanical actuation systems
Human machine interface
Linear motors
Stepper motors, servo motors, drives & controls
Structural extrusions



Filtration

Key Markets

Aerospace
Food & beverage
Industrial plant & equipment
Life sciences
Marine
Mobile equipment
Oil & gas
Power generation & renewable energy
Process
Transportation
Water Purification

Key Products

Analytical gas generators
Compressed air filters & dryers
Engine air, coolant, fuel & oil filtration systems
Fluid condition monitoring systems
Hydraulic & lubrication filters
Hydrogen, nitrogen & zero air generators
Instrumentation filters
Membrane & fiber filters
Microfiltration
Sterile air filtration
Water desalination & purification filters & systems



Fluid & Gas Handling

Key Markets

Aerial lift
Agriculture
Bulk chemical handling
Construction machinery
Food & beverage
Fuel & gas delivery
Industrial machinery
Life sciences
Marine
Mining
Mobile
Oil & gas
Renewable energy
Transportation

Key Products

Check valves
Connectors for low pressure fluid conveyance
Deep sea umbilicals
Diagnostic equipment
Hose couplings
Industrial hose
Mooring systems & power cables
PTFE hose & tubing
Quick couplings
Rubber & thermoplastic hose
Tube fittings & adapters
Tubing & plastic fittings



Hydraulics

Key Markets

Aerial lift
Agriculture
Alternative energy
Construction machinery
Forestry
Industrial machinery
Machine tools
Marine
Material handling
Mining
Oil & gas
Power generation
Refuse vehicles
Renewable energy
Truck hydraulics
Turf equipment

Key Products

Accumulators
Cartridge valves
Electrohydraulic actuators
Human machine interfaces
Hybrid drives
Hydraulic cylinders
Hydraulic motors & pumps
Hydraulic systems
Hydraulic valves & controls
Hydrostatic steering
Integrated hydraulic circuits
Power take-offs
Power units
Rotary actuators
Sensors



Pneumatics

Key Markets

Aerospace
Conveyor & material handling
Factory automation
Life science & medical
Machine tools
Packaging machinery
Transportation & automotive

Key Products

Air preparation
Brass fittings & valves
Manifolds
Pneumatic accessories
Pneumatic actuators & grippers
Pneumatic valves & controls
Quick disconnects
Rotary actuators
Rubber & thermoplastic hose & couplings
Structural extrusions
Thermoplastic tubing & fittings
Vacuum generators, cups & sensors



Process Control

Key Markets

Alternative fuels
Biopharmaceuticals
Chemical & refining
Food & beverage
Marine & shipbuilding
Medical & dental
Microelectronics
Nuclear Power
Offshore oil exploration
Oil & gas
Pharmaceuticals
Power generation
Pulp & paper
Steel
Water/wastewater

Key Products

Analytical Instruments
Analytical sample conditioning products & systems
Chemical injection fittings & valves
Fluoropolymer chemical delivery fittings, valves & pumps
High purity gas delivery fittings, valves, regulators & digital flow controllers
Industrial mass flow meters/controllers
Permanent no-weld tube fittings
Precision industrial regulators & flow controllers
Process control double block & bleeds
Process control fittings, valves, regulators & manifold valves



Sealing & Shielding

Key Markets

Aerospace
Chemical processing
Consumer
Fluid power
General industrial
Information technology
Life sciences
Microelectronics
Military
Oil & gas
Power generation
Renewable energy
Telecommunications
Transportation

Key Products

Dynamic seals
Elastomeric o-rings
Electro-medical instrument design & assembly
EMI shielding
Extruded & precision-cut, fabricated elastomeric seals
High temperature metal seals
Homogeneous & inserted elastomeric shapes
Medical device fabrication & assembly
Metal & plastic retained composite seals
Shielded optical windows
Silicone tubing & extrusions
Thermal management
Vibration dampening

Parker Worldwide

Europe, Middle East, Africa

AE – United Arab Emirates, Dubai
Tel: +971 4 8127100
parker.me@parker.com

AT – Austria, St. Florian
Tel: +43 (0)7224 66201
parker.austria@parker.com

AZ – Azerbaijan, Baku
Tel: +994 50 2233 458
parker.azerbaijan@parker.com

BE/NL/LU – Benelux, Hendrik Ido Ambacht
Tel: +31 (0)541 585 000
parker.nl@parker.com

BG – Bulgaria, Sofia
Tel: +359 2 980 1344
parker.bulgaria@parker.com

BY – Belarus, Minsk
Tel: +48 (0)22 573 24 00
parker.poland@parker.com

CH – Switzerland, Etoy
Tel: +41 (0)21 821 87 00
parker.switzerland@parker.com

CZ – Czech Republic, Klecany
Tel: +420 284 083 111
parker.czechrepublic@parker.com

DE – Germany, Kaarst
Tel: +49 (0)2131 4016 0
parker.germany@parker.com

DK – Denmark, Ballerup
Tel: +45 43 56 04 00
parker.denmark@parker.com

ES – Spain, Madrid
Tel: +34 902 330 001
parker.spain@parker.com

FI – Finland, Vantaa
Tel: +358 (0)20 753 2500
parker.finland@parker.com

FR – France, Contamine s/Arve
Tel: +33 (0)4 50 25 80 25
parker.france@parker.com

GR – Greece, Piraeus
Tel: +30 210 933 6450
parker.greece@parker.com

HU – Hungary, Budaörs
Tel: +36 23 885 470
parker.hungary@parker.com

IE – Ireland, Dublin
Tel: +353 (0)1 466 6370
parker.ireland@parker.com

IL – Israel
Tel: +39 02 45 19 21
parker.israel@parker.com

IT – Italy, Corsico (MI)
Tel: +39 02 45 19 21
parker.italy@parker.com

KZ – Kazakhstan, Almaty
Tel: +7 7273 561 000
parker.easteurope@parker.com

NO – Norway, Asker
Tel: +47 66 75 34 00
parker.norway@parker.com

PL – Poland, Warsaw
Tel: +48 (0)22 573 24 00
parker.poland@parker.com

PT – Portugal
Tel: +351 22 999 7360
parker.portugal@parker.com

RO – Romania, Bucharest
Tel: +40 21 252 1382
parker.romania@parker.com

RU – Russia, Moscow
Tel: +7 495 645-2156
parker.russia@parker.com

SE – Sweden, Borås
Tel: +46 (0)8 59 79 50 00
parker.sweden@parker.com

SK – Slovakia, Banská Bystrica
Tel: +421 484 162 252
parker.slovakia@parker.com

SL – Slovenia, Novo Mesto
Tel: +386 7 337 6650
parker.slovenia@parker.com

TR – Turkey, Istanbul
Tel: +90 216 4997081
parker.turkey@parker.com

UA – Ukraine, Kiev
Tel: +48 (0)22 573 24 00
parker.poland@parker.com

UK – United Kingdom, Warwick
Tel: +44 (0)1926 317 878
parker.uk@parker.com

ZA – South Africa, Kempton Park
Tel: +27 (0)11 961 0700
parker.southafrica@parker.com

North America

CA – Canada, Milton, Ontario
Tel: +1 905 693 3000

US – USA, Cleveland
Tel: +1 216 896 3000

Asia Pacific

AU – Australia, Castle Hill
Tel: +61 (0)2-9634 7777

CN – China, Shanghai
Tel: +86 21 2899 5000

HK – Hong Kong
Tel: +852 2428 8008

IN – India, Mumbai
Tel: +91 22 6513 7081-85

JP – Japan, Tokyo
Tel: +81 (0)3 6408 3901

KR – South Korea, Seoul
Tel: +82 2 559 0400

MY – Malaysia, Shah Alam
Tel: +60 3 7849 0800

NZ – New Zealand, Mt Wellington
Tel: +64 9 574 1744

SG – Singapore
Tel: +65 6887 6300

TH – Thailand, Bangkok
Tel: +662 186 7000

TW – Taiwan, Taipei
Tel: +886 2 2298 8987

South America

AR – Argentina, Buenos Aires
Tel: +54 3327 44 4129

BR – Brazil, Sao Jose dos Campos
Tel: +55 800 727 5374

CL – Chile, Santiago
Tel: +56 2 623 1216

MX – Mexico, Toluca
Tel: +52 72 2275 4200

EMEA Product Information Centre

Free phone: 00 800 27 27 5374

(from AT, BE, CH, CZ, DE, DK, EE, ES, FI, FR, IE, IL, IS, IT, LU, MT, NL, NO, PL, PT, RU, SE, SK, UK, ZA)

US Product Information Centre

Toll-free number: 1-800-27 27 537

www.parker.com

Your local authorized Parker distributor

